



**ASSEMBLY DIAGRAM AND ASSEMBLY REFERENCE
ULTIMA® 2" LATE MODEL
06'-PRESENT DYNA®, 07'-PRESENT SOFTAIL®**



Part #

06'-Present Dyna, 07'-Present Softail®

58-960 2" Late Model Belt Drive, Billet, Polished.

58-990 2" Late Model Belt Drive, Billet, Black.

Revised 11-26-24

Assembly Diagram and Assembly Reference

Ultima[®] Late Model 2" Belt Drive Units

Warranty Provisions

Ultima's component parts used in our Belt Drives are guaranteed to the original purchaser to be free of manufacturing defects in materials and workmanship for a period of Twelve (12) months from the date of purchase through Midwest Motorcycle Supply.

Merchandise that fails to conform to these conditions will be repaired by Ultima if the parts are returned to Midwest Motorcycle Supply by the purchaser within the 12-month warranty period or within 10 days thereafter. Some problems can be rectified by a telephone call and need no further course of action. A part that is suspected of being defective must not be replaced by a Dealer without prior authorization from Midwest Motorcycle Supply. If it is deemed necessary for Ultima to make an evaluation to determine whether the part was defective, it must be packaged properly to prevent further damage and be returned prepaid to Midwest Motorcycle Supply with a copy of the original invoice of purchase and detailed letter outlining the nature of the problem, how the part was used and the circumstances at the time of failure. If, after an evaluation has been made by Ultima and the part was found to be defective, repair or replacement will be granted at Ultima's discretion.

Additional Warranty Provisions:

1. Ultima shall have no obligation in the event an Ultima part is modified by any other person or organization.
2. Ultima shall have no obligation in the event an Ultima part becomes defective in whole or in part as a result of improper installation, improper maintenance, improper use, abnormal operation, or any other misuse or mistreatment of the Ultima part.
3. Ultima shall not be liable for any consequential or incidental damage resulting from the failure of an Ultima part, the breach of any warranties, the failure to deliver, delay in delivery, delivery in non-conforming condition, or for any other breach of contract or duty between Ultima and a customer.

Read Before Beginning Installation

Professional Installation Requirements:

Ultima Belt Drives should be installed by trained professional mechanics into motorcycle in which they were intended for use. Failure to do so may result in injury and even death. It is the customer's responsibility to insure their mechanic has proper training.

Preparation for Assembly

Before installing the Ultima Belt Drive System you must remove your entire existing primary drive. This also includes removing the pressed on transmission mainshaft race used with chain drive inner primary bearings. At this time we suggest inspection of your Charging System. This is also a great time to inspect the transmission sprocket and seal for wear and to ensure the sprocket is tight. Always disconnect the battery negative cables when performing any primary drive maintenance.

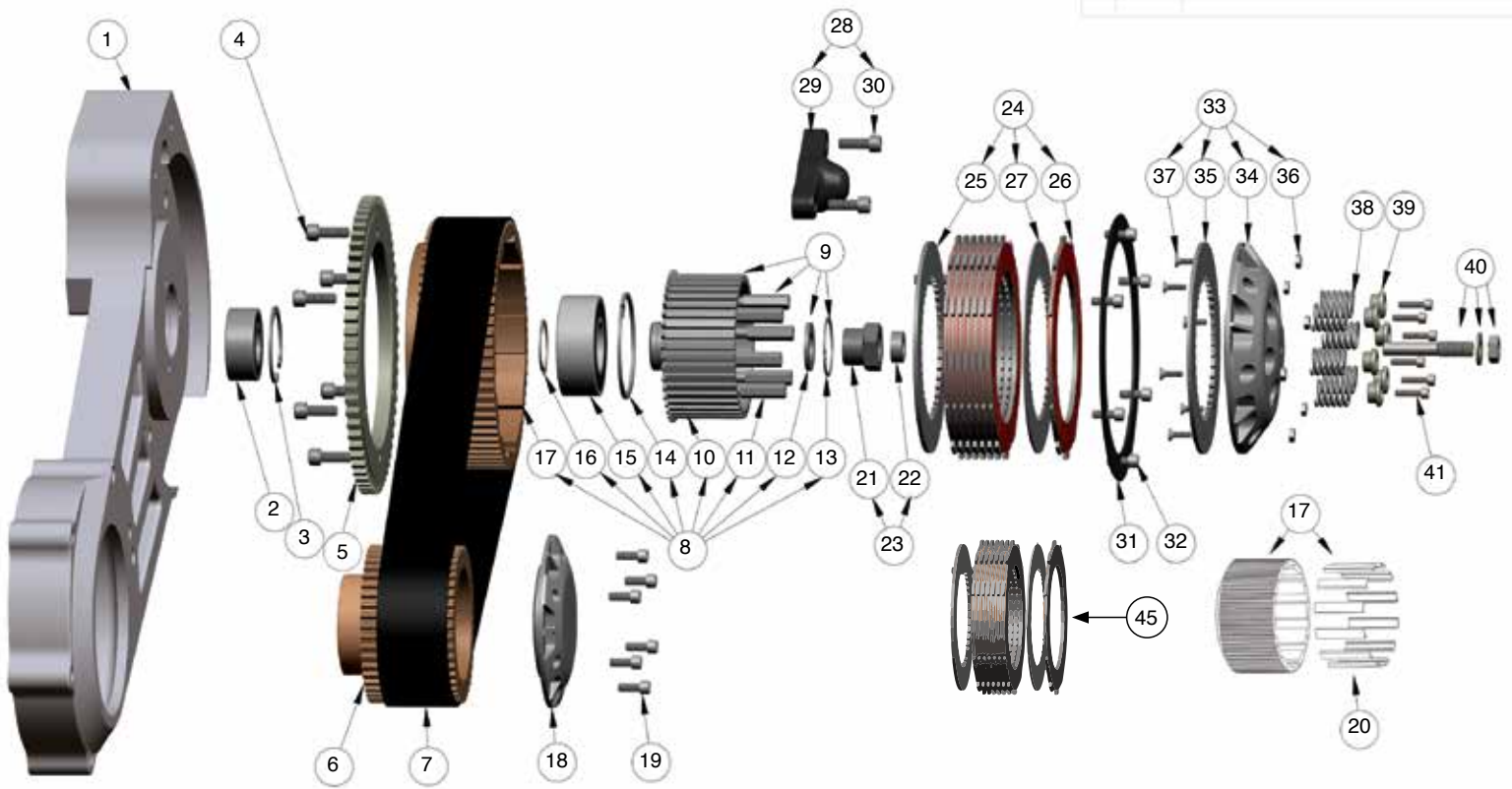

Item #	Qty.	Part #	BLACK #	Component	Item #	Qty.	Part #	BLACK #	Component
1	1	58-963	58-668	Motor Plate-Billet	23	1	58-622		Clutch Retaining Nut Assy
1	1	58-986	58-667	Motor Plate Assembly	24	1	58-769		Complete Replacement Clutch Assy
2	1	58-964		Bearing for 2008-Later, ID=24.82	25	1	-----		Clutch Drive Plate, Steel Lower 0.119
3	1	58-707		Bearing for 1990-2007, ID=25.02	26	8	-----		Clutch Plate, Friction
4	12	58-736		HX-SHCS 0.25-20 x 0.625 x 0.625-S	27	7	-----		Clutch Plate, Steel 0.049
5	1	58-976		Gear, Starter Ring	28	1	58-987	58-669	Cover Assembly, Starter Gear
6	1	58-970		Pulley, Motor 53T 2" Drive	29	1	-----	58-670	Cover, Starter Gear,billet
7	1	58-985		Belt, Ultima® 2" 8mm 140t -4	30	2	58-798		HX-SHCS 0.3125-18 x 0.75 x 0.75-S
8	1	58-971		Complete Trans Pulley Assembly	31	1	58-980		Belt Guide, Ultima 2" Steel/Chrome
9	1	58-972		Clutch Hub Assembly	32	6	58-736		HX-SHCS 0.25-20 x 0.625 x 0.625-S
10	1	58-973		Clutch Hub	33	1	58-977	58-671	Pressure Plate Assembly
11	6	58-833		Clutch Spring Stud	34	1	58-978	58-672	Pressure Plate, billet
12	1	58-756		Washer, Clutch Hub	35	1	58-772		Clutch Drive Plate, Upper
13	1	58-757		N5000-137 Snap Ring	36	6	58-773		MSHXNUT 0.164-32-S-N
14	1	58-738		Retaining Ring, Clutch Assy Outer	37	6	58-774		SCHCSREW 0.164-32 x 0.625 x 0.625-HX-S
15	1	58-737		Bearing, Ball, Double Row Angular Contact	38	6	96-251		Spring, Clutch, Medium
16	1	58-739		Retaining Ring, Clutch Assy Inner	6	6	96-249		Spring, Clutch, Heavy Duty
17	1	58-975		Pulley, Transmission 72T with insert	6	6	96-250		Spring, Clutch, Extra Heavy Duty
18	1	58-981	58-673	Motor Pulley Cap, billet	39	6	58-852		Clutch Spring Guide
19	6	58-736		HX-SHCS 0.25-20 x 0.625 x 0.625	40	1	58-779		Clutch Adjuster Assy
20	1	58-925		S/S Pulley Inserts, 2"	41	6	58-835		SHCS M6X25
21	1	58-741		HTNUT 0.75-16-D-S	42	1	58-982		Pulley Bolt Washer 1.98"x.59"x.30" black oxide coated
22	1	95-778		Clutch Rod Seal	43	1	58-983		Spacer 2.86"x1.25"x.35" black oxide coated
					44	1	58-984		Spacer 2.86"x1.25"x.13" zinc plated
					45	1	58-732		Complete Replacement Clutch Assy

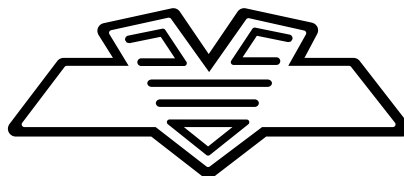

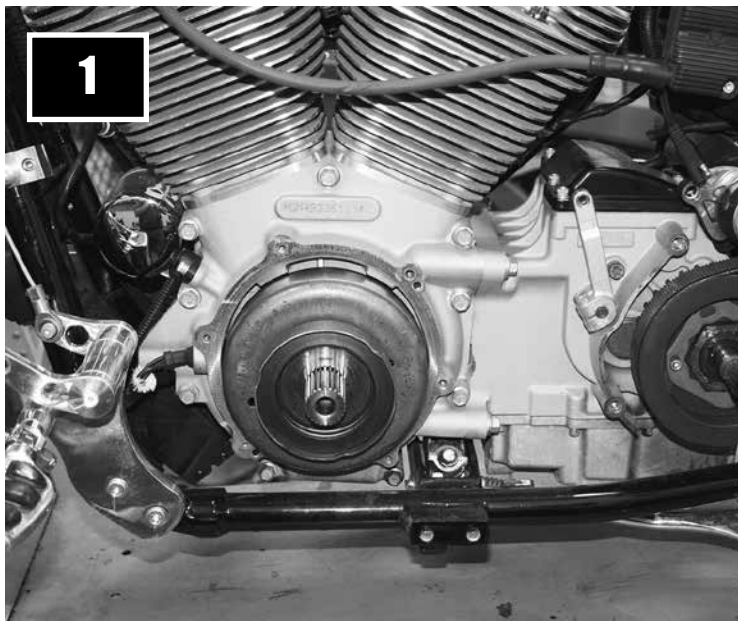

1. Unplug Battery Negative Cables

Remove stock primary drive per the manufacturers guidelines.
Remove inner primary bearing race from transmission main shaft.



2.

Install the appropriate supplied motor plate bearing & circlip for your application into the motor plate. 07-earlier / 08-later models use different bearings.

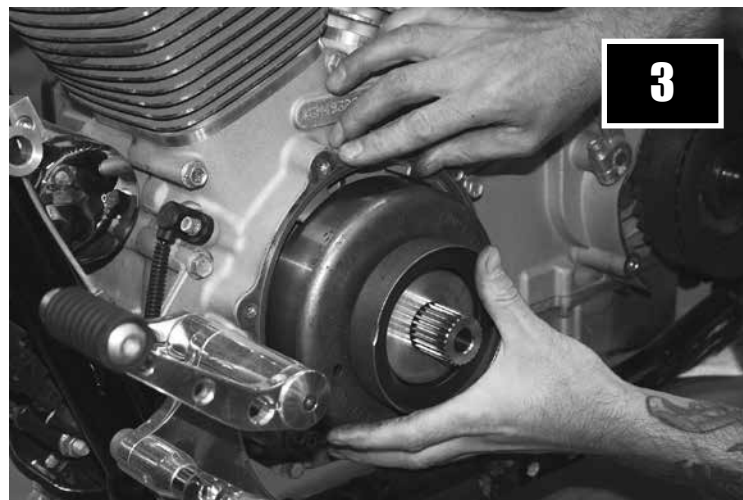

3.

Install OEM inner primary to engine gasket.



4.

Install the motor plate & install the mounting bolts using red threadlocker. Torque to manufacturers specs.

4A.

At this time, you will reinstall your starter to the motor plate.

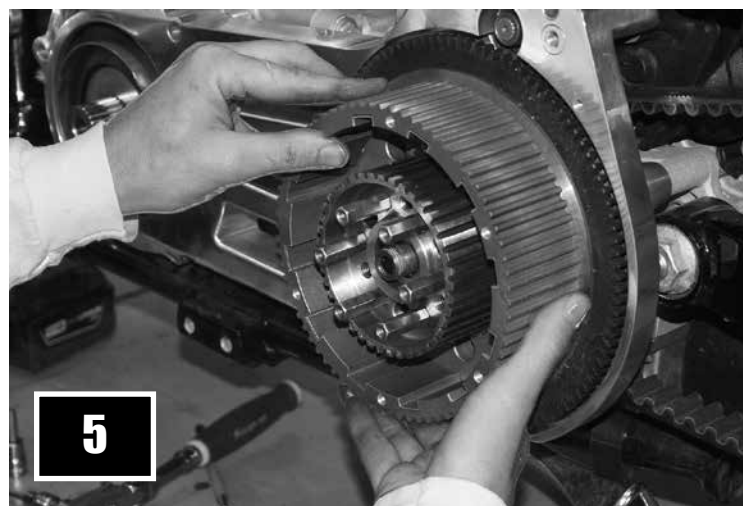

5.

Install clutch basket assembly onto the transmission mainshaft.

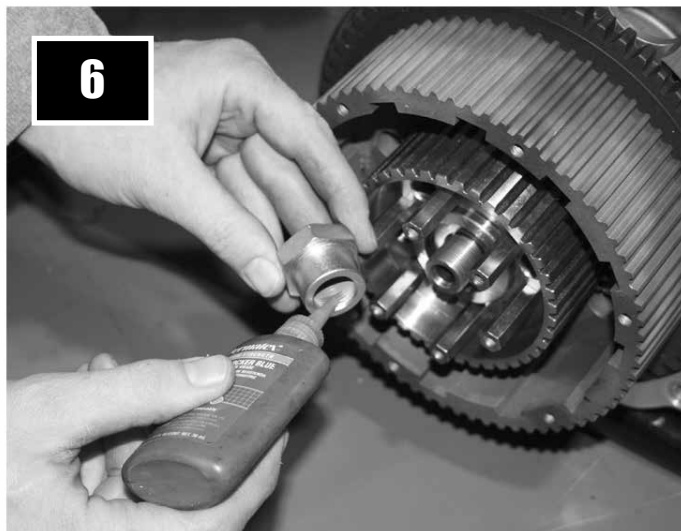

6.
Install & torque mainshaft nut to 55-65 ft-lbs using red thread locker.

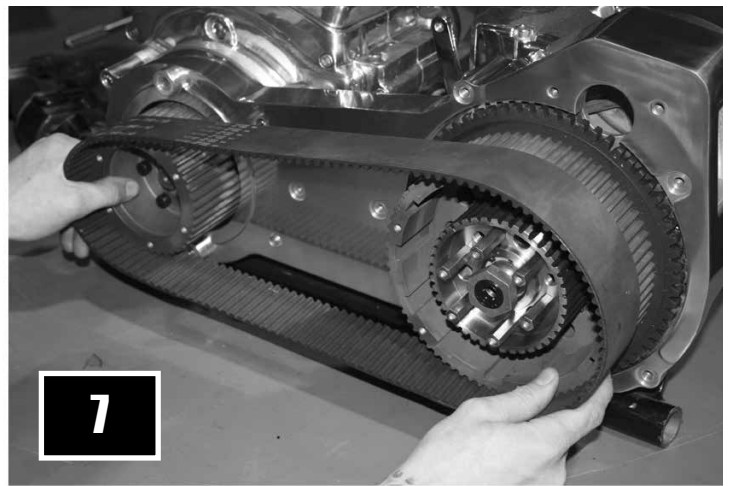

7.
Install front motor pulley & belt.

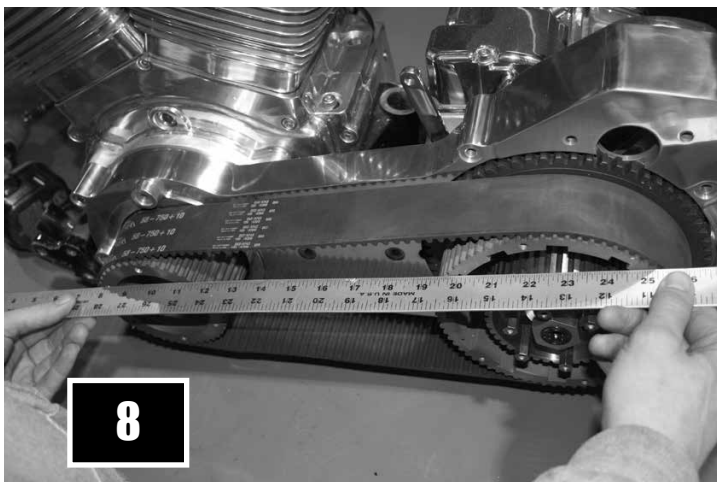

8.
Verify alignment of the two pulleys & shim front motor pulley if necessary. (2 spacers included with kit)



9.
Install & torque the OEM compensator bolt to manufacturers specs. Always clean bolt thoroughly and apply red thread locker before installing.

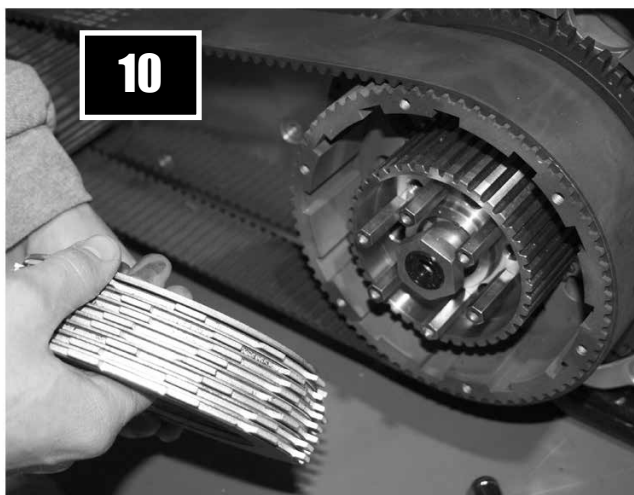

10.
Ultima 2" belt drives utilize 8 steel & 8 friction plates. When installing the clutch pack, install the thick .119" steel plate first then alternate friction & steel. The last plate you should install should be fiber/friction.



11.
Install the clutch adjusting screw using a small amount of high temp grease or antisieze on the threads & on the clutch pushrod end.

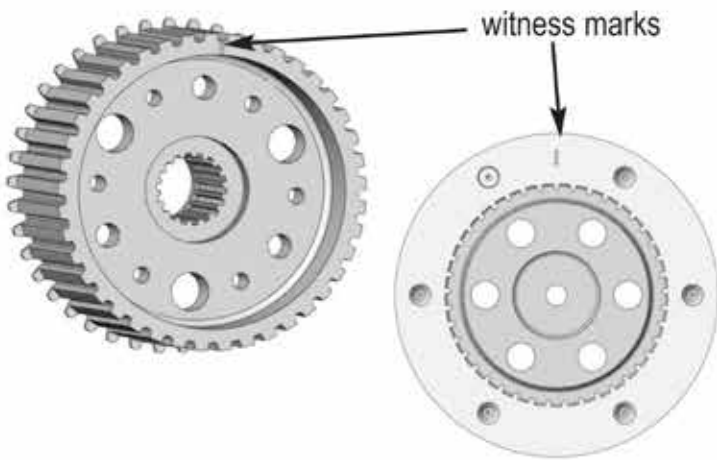

- 12.** Align the witness marks on the pressure plate and inner clutch hub as shown when installing pressure plate. This will ensure clutch hub studs will be centered in the appropriate pressure plate holes.

NOTE: CENTER PUSHROD IS REQUIRED

The center clutch push rods (located in the transmission main shaft) may need to be changed depending on setup. Below is a list of available sizes.

<u>PART#</u>	<u>LENGTH</u>	<u>DESCRIPTION</u>
96-442	11.375"	1987-1989 5 speed
96-538	10.8125"	1990+ 5 speed



- 13.** After installing pressure plate, install clutch springs w/supplied spring collars and narrow-headed 12-24 bolts. Install using Blue Locktite. Spring collars should bottom on clutch hub studs. Torque to 90 in-lbs. In higher horsepower applications, heavier springs are available.
 Midwest Part#96-251 (68lbs @ 1")
 Midwest Part#96-249 (82lbs @ 1")

Midwest Part#96-250 (98lbs @ 1")



14.
Install the chromed belt guide using blue thread locker on the bolts.



15.
Install the starter jackshaft cover using blue thread locker on the bolts.

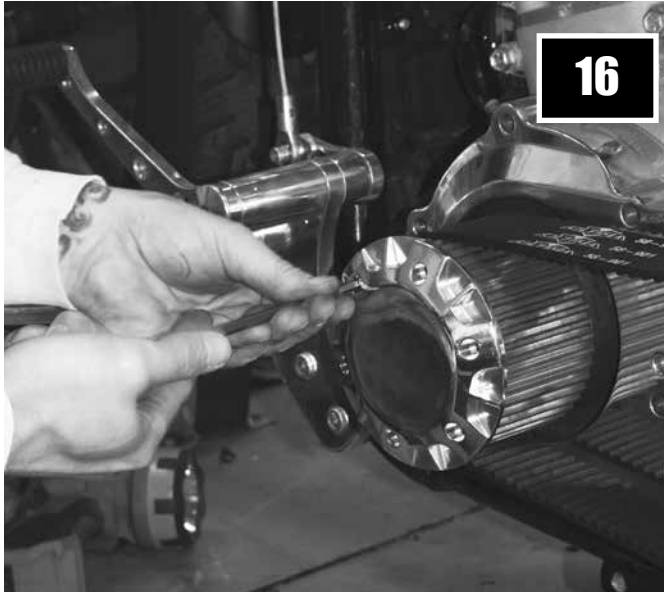

16.
Install the motor pulley cap using blue thread locker on the bolts.

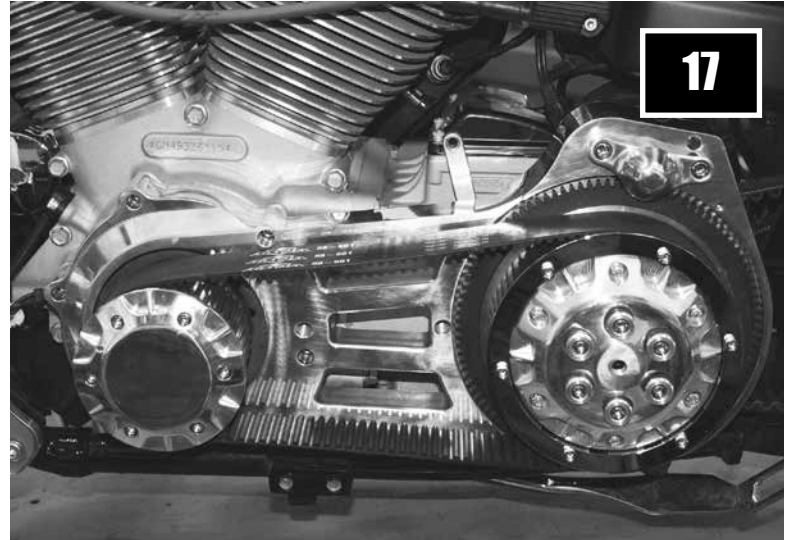

17.
At this time you will adjust the clutch at the basket. Once that has been completed, remove any excess freeplay at the lever by adjusting the clutch cable.



Ultima Company LLC is not a representative of any other motorcycle manufacturer and the parts we sell are not necessarily recommended by any other motorcycle manufacturer. All words used in this catalog denoting any motorcycle manufacturer, models of motorcycle, or part numbers are intended for use as reference only.

Harley-Davidson® Parts: Harley® and Harley-Davidson® and other model names of Harley® motorcycles are used as a reference only. Some H-D® part numbers are also used as reference only. We are not an authorized Harley® dealer and in no way do we have, or intend to imply any kind of business relationship with Harley-Davidson Motor Company®. Our intention is to provide products that can be used on a Harley-Davidson® motorcycle.

Names and words that are registered trademarks of Harley-Davidson® Inc. Milwaukee, WI, such as Evolution®, Harley-Davidson®, Harley®, H-D®, HD®, and Softail® are not intended to imply that they are Harley-Davidson® original equipment by their use in connection with Harley-Davidson® factory part numbers. All other trademarks, registered trademarks and brand names used in this catalog are the property of their respective holders.

WARNING

Serious injury, death and property damage can result from the improper use, control, alteration, or maintenance of motorcycles. The dealer and dealers customers must exercise good judgement in the use, control, alteration, part selection and installation, and maintenance of motorcycles. Ultima® has no control over the judgement of others and assumes no responsibility or liability of any nature for the failure of others to use good judgement.

COPYRIGHT ULTIMA® COMPANY LLC 2024

